

CIRCUIT DIAGRAM FOR COBRA 29LTD

REVISION RECORD		
UPDATE TO ECN NO.	APPROVED:	DATE:
ECN-29LST-668		

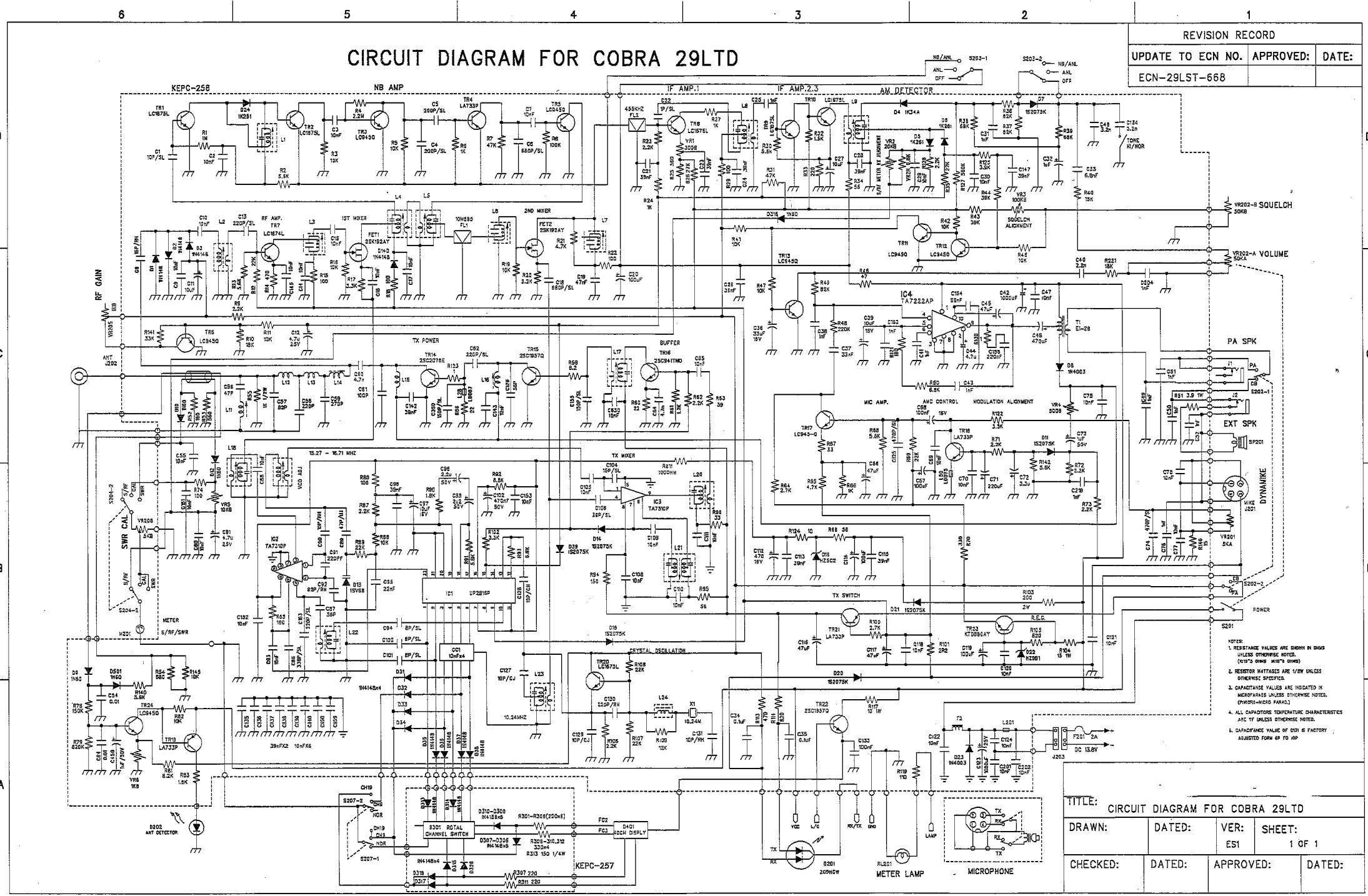

TITLE: CIRCUIT DIAGRAM FOR COBRA 29LTD			
DRAWN:	DATED:	VER:	SHEET:
		ES1	1 OF 1
CHECKED:	DATED:	APPROVED:	DATED: